

Archives Doc: Eastgate Master Plan/Revised/BDP/A21043\_Eastgate Squa... Master Plan\_A2022.rvt

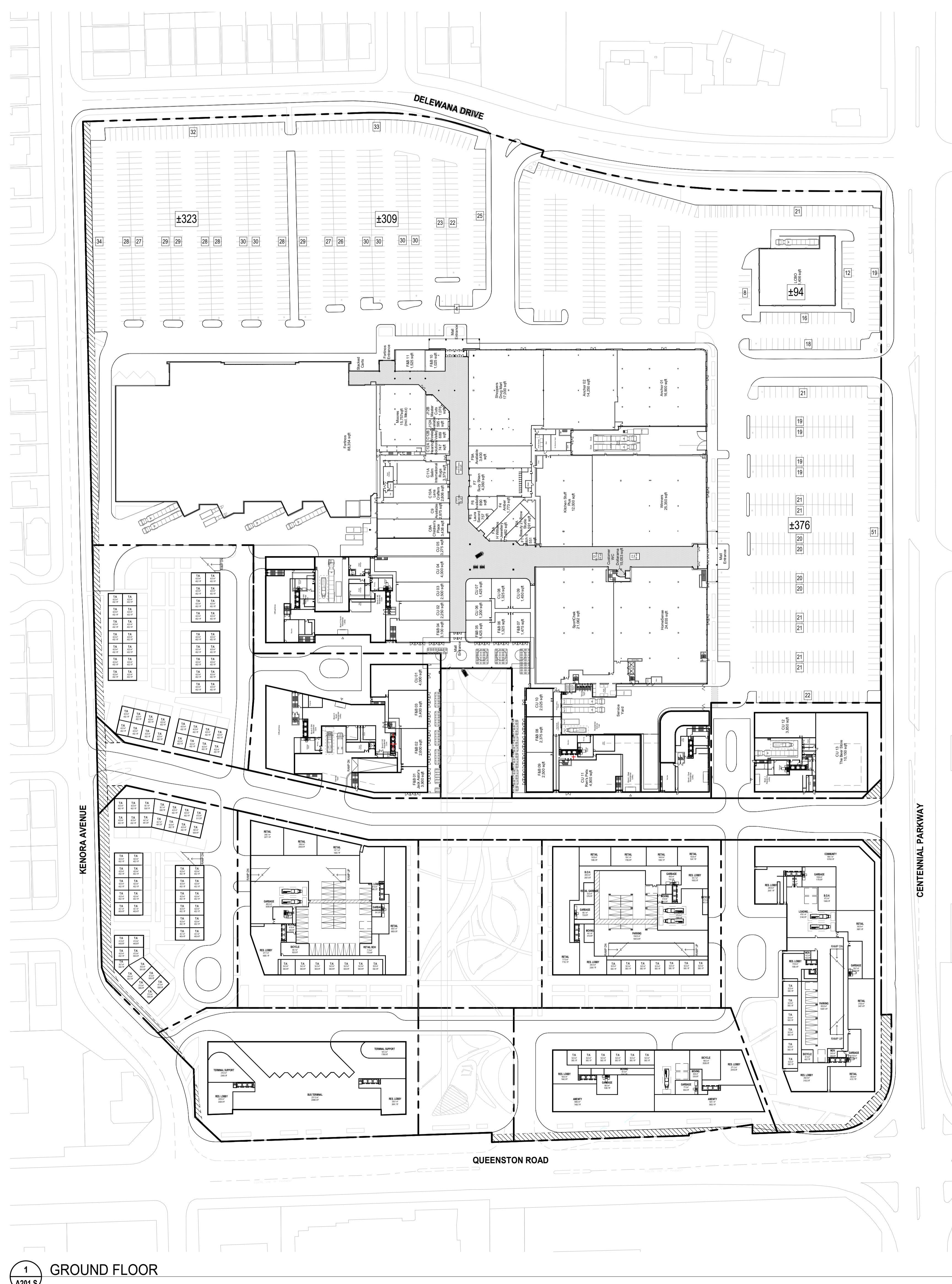

1 GROUND FLOOR  
A201.S

**PARKING NOTES:**  
1. MINIMUM PARKING SPACE SIZES (UNLESS OTHERWISE NOTED):  
- 2000mm WIDE X 5000mm LONG (NO SIDES OBSTRUCTED)  
- 2000mm WIDE X 5000mm LONG (ONE SIDE OBSTRUCTED)  
- 2500mm WIDE X 5000mm LONG (TWO SIDES OBSTRUCTED)  
2. MAINTAIN MINIMUM DRIVE AISLE WIDTH OF 6000mm UNLESS OTHERWISE NOTED.  
3. MAINTAIN MINIMUM HEADROOM CLEARANCE OF 2100mm THROUGHOUT.

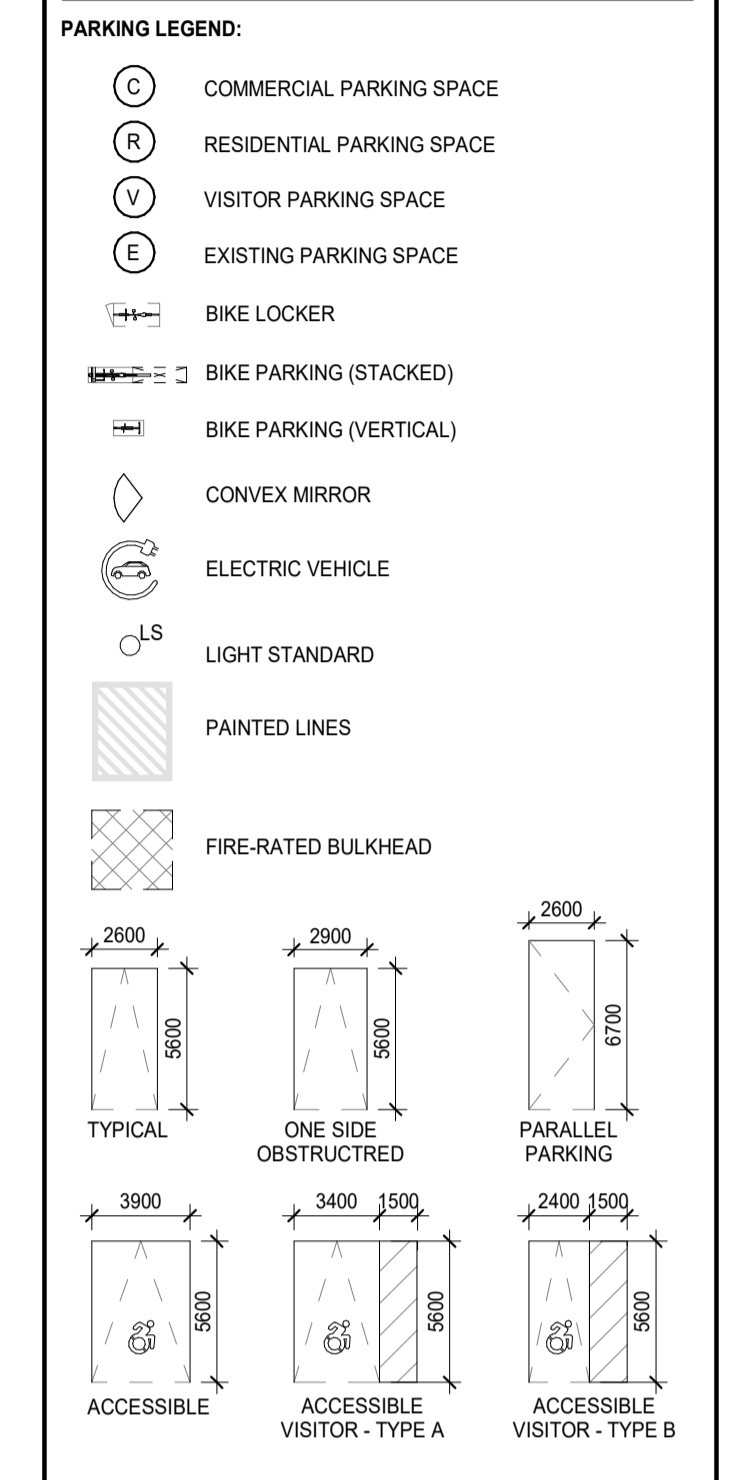

REVISION RECORD

ISSUE RECORD

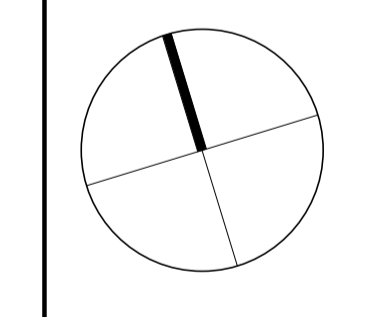

**BDP  
Quadrangle**

Quadrangle Architects Limited  
801 King Street West, Suite 701 Toronto, ON M5V 3H5  
416-598-1200 www.bdpquadrangle.com

Eastgate Square Master Plan  
East Hamilton, Ontario  
for Harrison Equity Partners

21043 As indicated/VT  
PROJECT SCALE DRAWN REVIEWED

Overall Typical Parking Plan and  
Overall Ground Floor Plan

**A201.S**

Note: This drawing is the property of the Architect and may not be reproduced or used without the expressed consent of the Architect. The Contractor is responsible for checking and verifying all measurements and dimensions and shall report all discrepancies to the Architect one day prior to commencing work.

05/10/2022 2:29:00 PM